

PREPARED BY: _____ DATE _____	<h1>SHARP</h1> <p>ELECTRONIC COMPONENTS GROUP</p> <p>SHARP CORPORATION</p> <h2>SPECIFICATION</h2>	SPEC No. LC63620A
APPROVED BY: _____ DATE _____		FILE No. _____
		ISSUE July. 8, 1988
		PAGE 20
		REPRESENTATIVE DIVISION
		<input type="checkbox"/> IC DIV. <input type="checkbox"/> SEMICONDUCTOR APPLICATION DIV. <input type="checkbox"/> DISPLAY DIV. <input type="checkbox"/> ELECTRONIC COMPONENTS DIV. 0

DEVICE SPECIFICATION FOR

240 X 128 Dots

LCD Dot-Matrix Unit

(. D-STN ,built in CCET backlight)

MODEL No.

LM2401 OZ

CUSTOMERS APPROVAL

DATE _____

BY _____

PRESENTED
BY H.N. Kajima

H. Naka jima
Department General Manager
Engineering Department 2
Liquid Crystal Display Division
ELECOM Group
SHARP CORPORATION

SHARP

1. Application

This data sheet is to introduce the specification of the Dot-Matrix LCD Unit. LM24010Z .

(240 X 128 dot, **D-STN** Transmissive negative type, With backlight system by cold cathode fluorescent tube (CCFT).)

2. Construction and Outline .

Construction : 240 X 128 full dot graphic display unit

Outline : See Fig. 8 .

Connection : See Fig. 8 and Table. 6 .

There shall be no scratches, **stains, chips**, distortions and other external drawbacks that may affect the display function.

Rejection criteria shall be noted in Inspection Standard S-U-007.



3. Mechanical Specifications

Table 1

Parameter	Specifications	Unit
Outline dimensions *1	176 (W) × 96 (H) × 22MAX (D)	mm
Effective viewing area	134 (W) × 76 (H)	mm
Display format	240(W) X128(H) full dot	
Dotsize	0.49(W) X0.49(H)	mm
Dot spacing	0.04	mm
Dot color *2	White	
Background color *2	Black	
Weight	approx. 430	g

*1 : Excluded the mounting tab and connector. (See Fig.8)

*2 : Due to the characteristics of the LC Material, the colors vary with environmental temperature.

4. Absolute Maximum Ratings

4-1. Electrical Absolute Maximum Ratings

Table 2

Parameter	Symbol	Min.	Max.	Unit	Remark
Supply voltage (Logic)	VDD-VSS	0	6.0	v	Ta=25°C
Supply voltage (LCD drive)	VDD-VEE	0	27.0	v	Ta=25°C
Input voltage	VIN	0	VDD	v	Ta=25°C



4-2. Environmental Condition

Table 3

Item	Tstg		Topr		Remark
	MIN.	MAX.	MIN.	MAX.	
Ambient temperature	-25°C	+60°C	0°C	+45°C	
Humidity	Note 1		"Note 1		No condensation
Vibration	Note 2		Note 2		3 directions (X/Y/Z)
Shock	Note 3		Note 3		6 directions (± X / ± Y / ± Z)

Note 1 $T_a \leq 40^\circ\text{C}$ 95% RH Max
 $T_a > 40^\circ\text{C}$ Absolute humidity shall be less than
 $T_a = 40^\circ\text{C} / 95\% \text{ RH}$

Note 2) Frequency : 10 ~ 55Hz
Vibration width : 1.5mm
Interval : 10Hz ~ 55Hz ~ 10Hz
(1 rein)
2 hours for each direction of X/Y/Z (6 hours as total)

Note 3) Direction of ± X : Accerelation 80G, Pulse width 6ms, 3 times.
Direction of ± Y / ± Z : Accerelation 100G, Pulse width 6ms,
3 times.



5. Electrical Specifications

5-1. Electrical characteristics

Table 4

Ta=25°C, VDD=5V±5%

Parameter	Symbol	Conditions	Min.	TYP.	Max.	Unit
Supply voltage (Logic)	VDD-VSS		4.75	5.0	5.25	v
Supply voltage (LCD drive)	VEE-VSS	VDD=5V Note)	-21	-	-	v
Input signal voltage	VIN	"H" level	0.8VDD		VDD	v
		"L" level	0		0.2VDD	v
Input leakage current	IIL	"H" level			20	μA
		"L" level	-20			μA
Supply current (Logic)	IDD	VEE=-21V VDD=5V		16	20	mA
Supply current (LCD drive)	IEE	F=80Hz VR=0Ω		15	18	mA
Power consumption	Pd	display high Frequency pattern		395	478	mW

Note) The viewing angle with optimum contrast(e) is available by changing Reference voltage for LCD drive circuit. And this Reference voltage varies by changing the resistance between terminal VR1 and VR2.

(Refer to Fig.4 for the definition of θ .)

5-2. Input capacitance

Table 5

Signal	Input capacitance
s	50PF TYP
CP1	100pF TYP
CP2	100pF TYP
D1~D4	50pF TYP

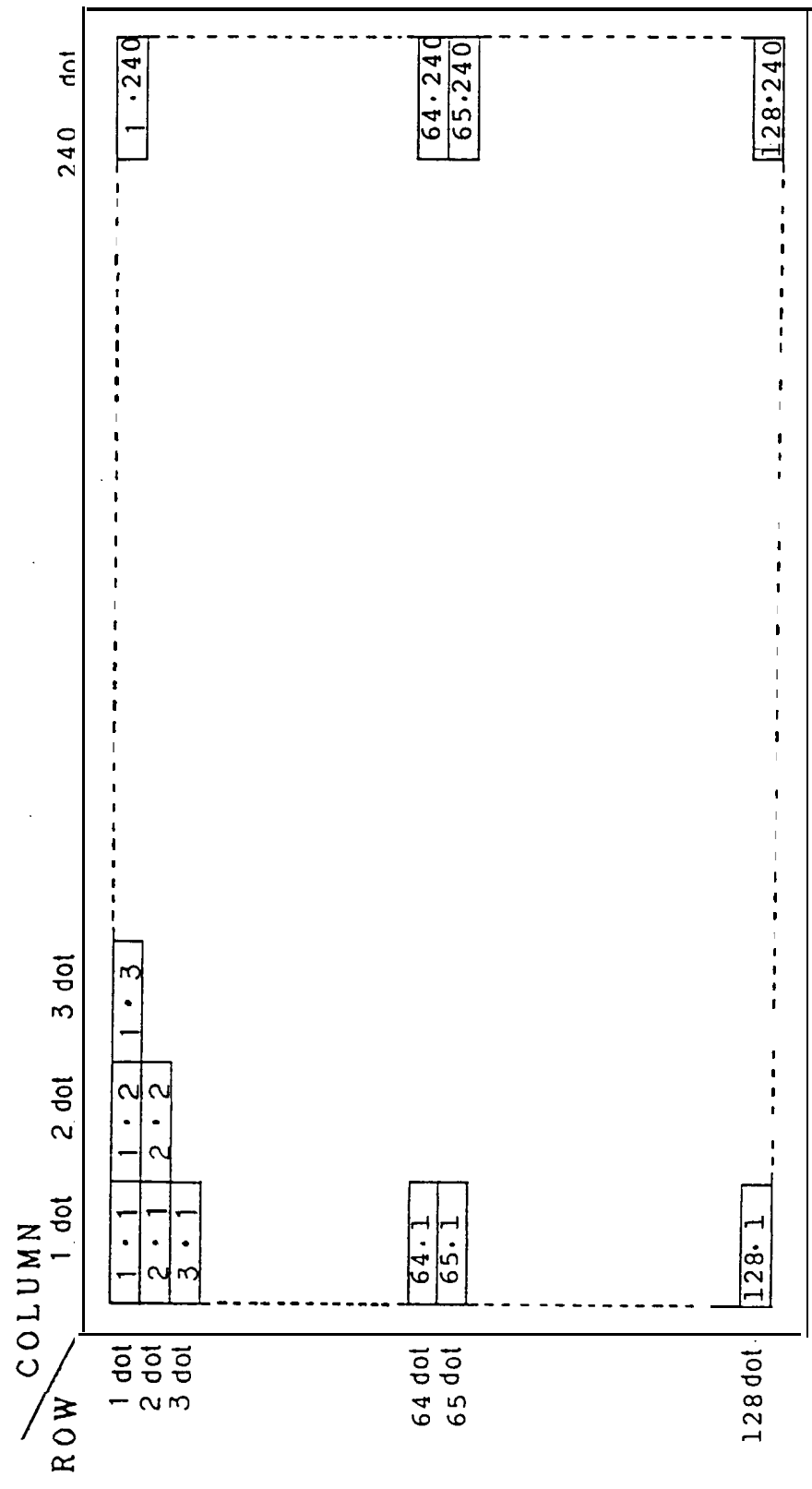

Note: 1 . 2 means 1st row 2nd column dot.

Fig 1 Dot Chart of Display Area

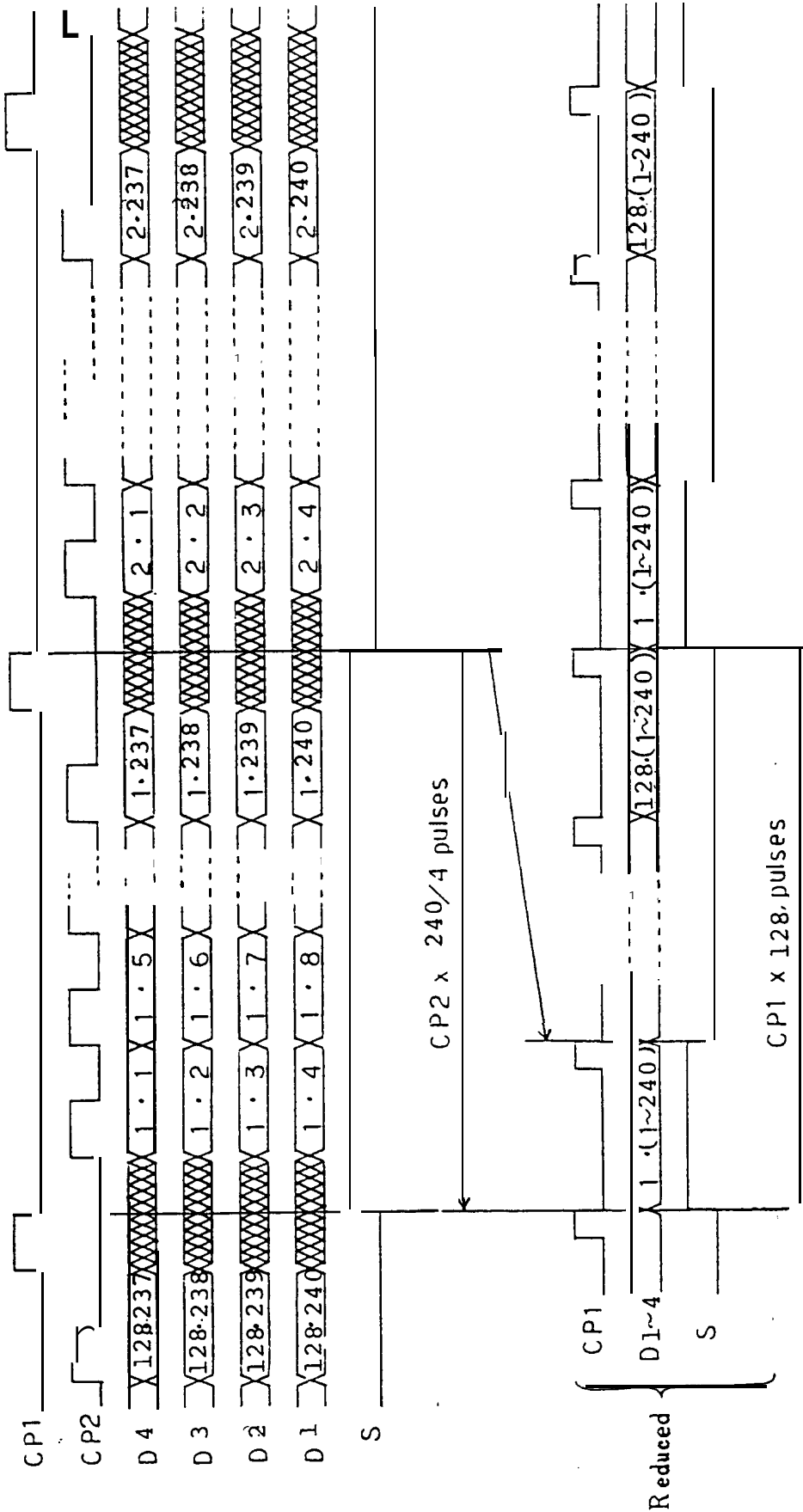

Fig 2 Data Input Timing

Table 7 Interface timing ratings

Item	symbol	Rating			Unit
		MIN .	TYP .	MAX.	
Frame cycle	TFRM	12.5		14.3	ms
CP ₂ clock cycle	TCP2	500			ns
"H" level clock width	tCWH	230			ns
"L" level clock width	tCWL	230			ns
"H" level latch clock width	tLWH	130			ns
Date set up time	tSU	100			ns
Date hold time	tH	100			ns
CP ₂ ↑ clock allowance time from CP ₁ ↓	tS12	0			ns
CP ₁ ↑ clock allowance time from CP ₂ ↓	tS21	0			ns
Clock rise/fall time	t _r ,t _f			50	ns

SHARP

6. Unit Driving Method

6.1 Circuit configuration

Fig.7 shows the block diagram of the Unit's circuitry.

6.2 Input data and control signals

The LCD driver is 80 bits LSI, consisting of shift registers, latch circuits and LCD drivers.

Display data which are externally divided into data for each row (240 dots) will be sequentially transferred in the form of 4-bit parallel data through shift registers by Clock Signal CP2 from the left top of the display face.

When data of one row (240 dots) have been inputted, then latched in the form of parallel data for 240 lines of signal electrodes by Latch Signal CP1. Then the corresponding drive signal will be transmitted to the 240 lines of column electrodes of the LCD panel by the LCD drive circuits.

At this time, scan start-up signal S has been transferred from the scan signal driver to the 1st row of scan electrodes, and the contents of the data signals are displayed on the 1st rows of the display face according to the combinations of voltages applied to the scan and signal electrodes of the LCD.

While the 1st rows of data are being displayed, the 2nd rows of data are entered. When 240 dots of data have been transferred then latched on the falling edge of CP1 clock, the display face proceeds to the 2nd rows of display.

Such data input will be repeated up to the 128th row of each display segment, from upper to lower rows, to complete one frame of display by-time sharing method. Then data input proceeds to the next display face.

Scan start-up Signal S generates scan signal to drive horizontal electrodes

The unit shall be driven at the speed of 70~80Hz/frame to avoid flickering.

Since DC voltage, if applied to LCD panel, causes chemical reaction which will deteriorate LCD panel, drive waveform shall be inverted at every display frame to prevent the generation of such DC voltage. And to prevent such problem. Drive AC waveform generation circuit by counted CP1(M generator) is build in this circuit.

Because of the characteristics of the CMOS driver LSI, the power consumption of the unit goes up as the operating frequency CP2 increases. Thus the driver LSI applies the system of transferring 4-bit parallel data through the 4 lines of shift registers to reduce the data transfer speed CP2. Thanks to the LSI, the power consumption of the unit will be minimized.

SHARP

In this circuit configuration, 4-bit display data shall be therefore inputted to data input pins of D1~D4.

Furthermore the LCD unit adopts bus line system for data input to minimize the power consumption. In this system data input terminal of each driver LSI is activated only when relevant data input is fed.

Data input for column electrodes of display segment and chip select of driver LSI are made as follows:

The driver LSI at the left end of the display face is first selected, and the adjacent driver LSI of the right side is selected when 80 dots data (20CP2) is fed. The process is sequentially continued until data is fed to the driver LSI at the right end of the display face.

This process is simultaneously followed at the column driver LSI's of display segments. Thus data input for display segments must be fed through 4-bit bus line sequentially from the left end of the display face.

Since this graphic display unit contains no refresh RAM, it requires data and timing pulse inputs even for static display.

The timing chart of input signals are shown in Fig.3.

SHARP

7. Optical Characteristics

V_{DD} = 5V
 V_{EE} = -21V
 (T_a = 25°C)

Table 8

Parameter	Symbol	Condition	Min.	Typ.	Max.	Unit	Remark	
Viewing angle range	$\theta_2 - \theta_1$	$\phi = 0^\circ$ $\theta_1 < \theta_2$	$C_0 \geq 5.0$	40	-	-	dgr.	Note 1
	θ_1		$C_0 = 5.0$	-	-	-15	dgr.	Note 1
	θ_2		20	-	-	dgr.	Note 1	
	$\theta_2 - \theta_1$	$\phi = 90^\circ$ $\theta_1 < \theta_2$	$C_0 \geq 5.0$	45	-	-	dgr.	Note 1
	θ_1		$C_0 = 5.0$	-	-	-20	dgr.	Note 1
	θ_2			20	-	-	dgr.	Note 1
Contrast ratio	C_0	$\theta = 0^\circ$	15	20	-	-	Note 2	
Response speed	Rise	T_r	$\theta = 0^\circ$	-	200	300	ms	Note 3
	Decay	T_d	$\theta = 0^\circ$	-	200	300	ms	Note 3

Note 1) The viewing angle range may be defined as shown below.

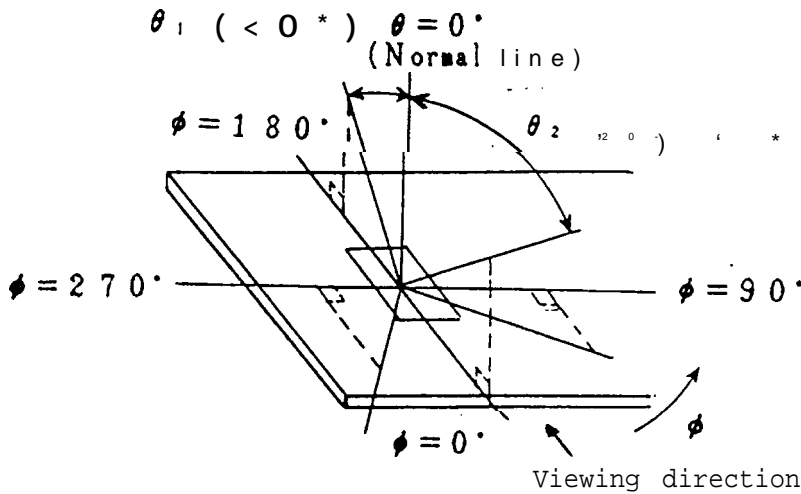

Angles θ_1 , θ_2 and ϕ shall fall within the range over which the displayed character can be read.

Fig. 4 Definition of Viewing Angle

Note 2) Contrast ratio may be defined as follows:

Contrast ratio is calculated by using the following formula when the waveform voltage (Fig. 6) is applied in the optical characteristics test method (Fig. 5).

$$\text{Contrast ratio} = \frac{\text{Photo-detector output voltage with select waveform being applied}}{\text{Photo-detector output voltage with non-select waveform being applied}}$$

SHARP

Note 3) The response characteristics of photo-detector output are measured as shown in Fig. 6, assuming that input signals are applied so as to select and deselect the dots to be measured, in the optical characteristics test method shown in Fig. 5.



Note 4) Table 8 shows the optical characteristics detected when the LCD applied voltage waveforms are in the highest frequency*.

* The most critical condition for the characteristics of LCD.

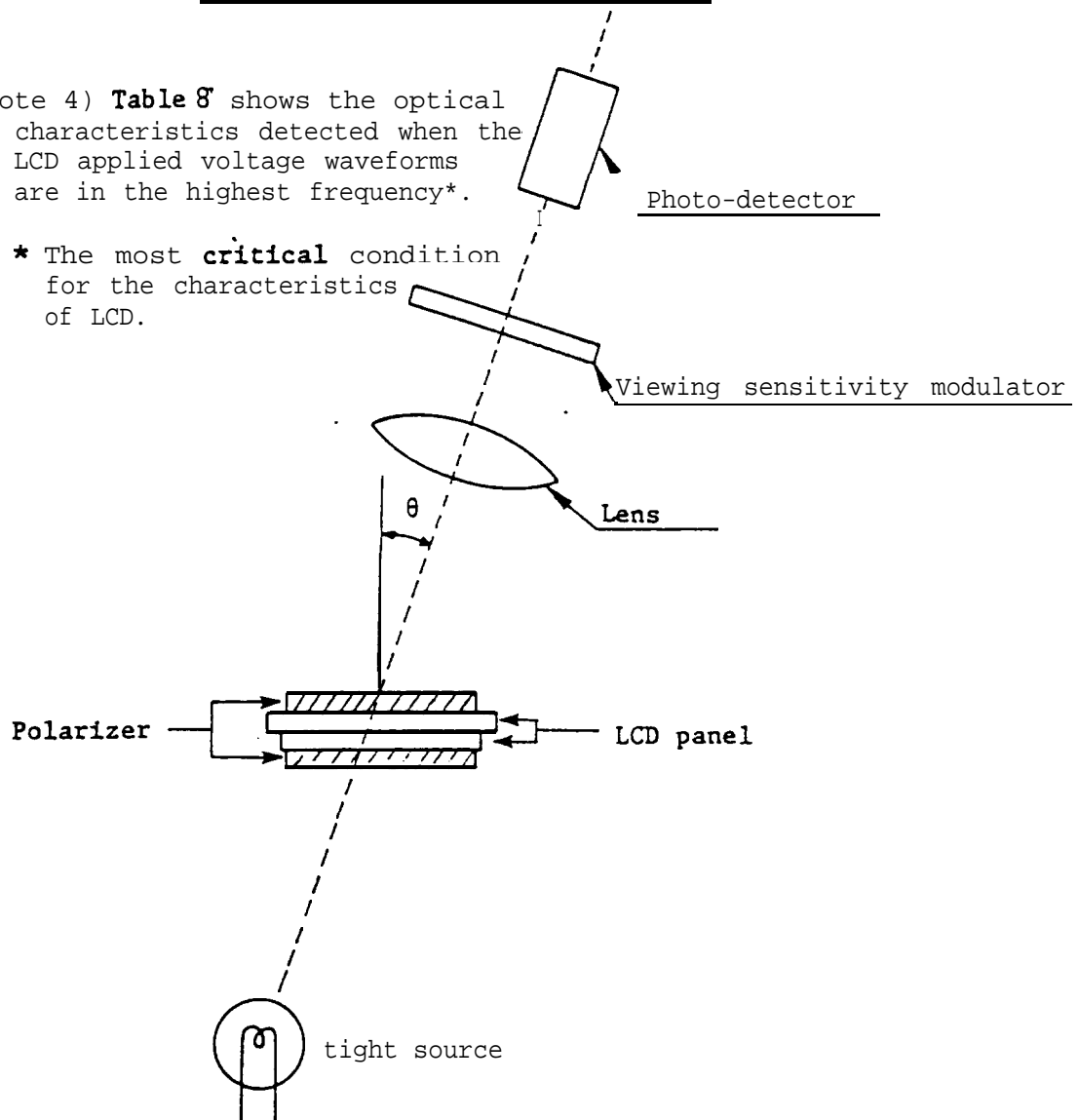

Fig. 5; Optical Characteristics Test Method

SHARP

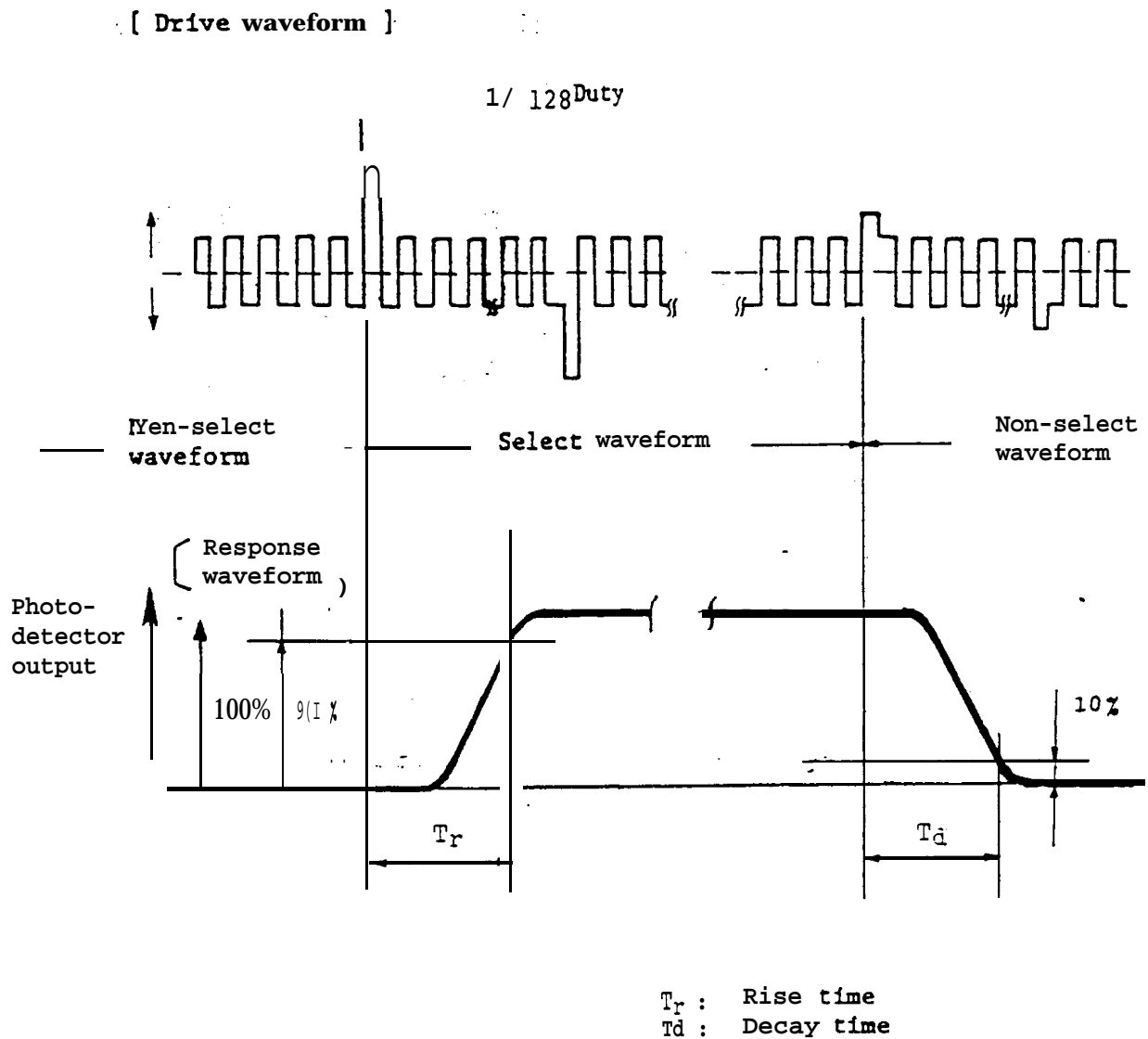

Fig.6 Definition of Response Time

SHARP

8. Characteristics of Backlight

The ratings are given on condition that the following conditions are satisfied.

8-1. Rating (Following Brightness specification is based upon active area.)

Parameter	Min.	TYP.	Max.	Unit
Brightness	10.0	- -	48.0	nt
Input current	-	90	99	mA

8-2. Measurement circuit (INSERTER)

CXA1301-1 (COPAL)

8-3. Measurement equipment (Brightness measurement equipment)

BM-5 (Tokyo Optical Machinery Corporation)

8-4. Measurement conditions

8-4-1. Measurement circuit voltage: DC=24V at primary side

8-4-2. LCD is displayed. The maximum contrast in $\theta=0^\circ$.

8-4-3. Ambient temperature: 25°C

Measurement shall be executed 30 minutes after turning on.

8-5. Life time

Life time to be 20,000 hours or more with CXA1301-1 (Rated current of 4.4mA).

*Definition of Life time

Life time shows following specified time period..

The brightness of lighting device will decrease to to 50% compared to initial brightness after operation for such time (Life time).

SHARP

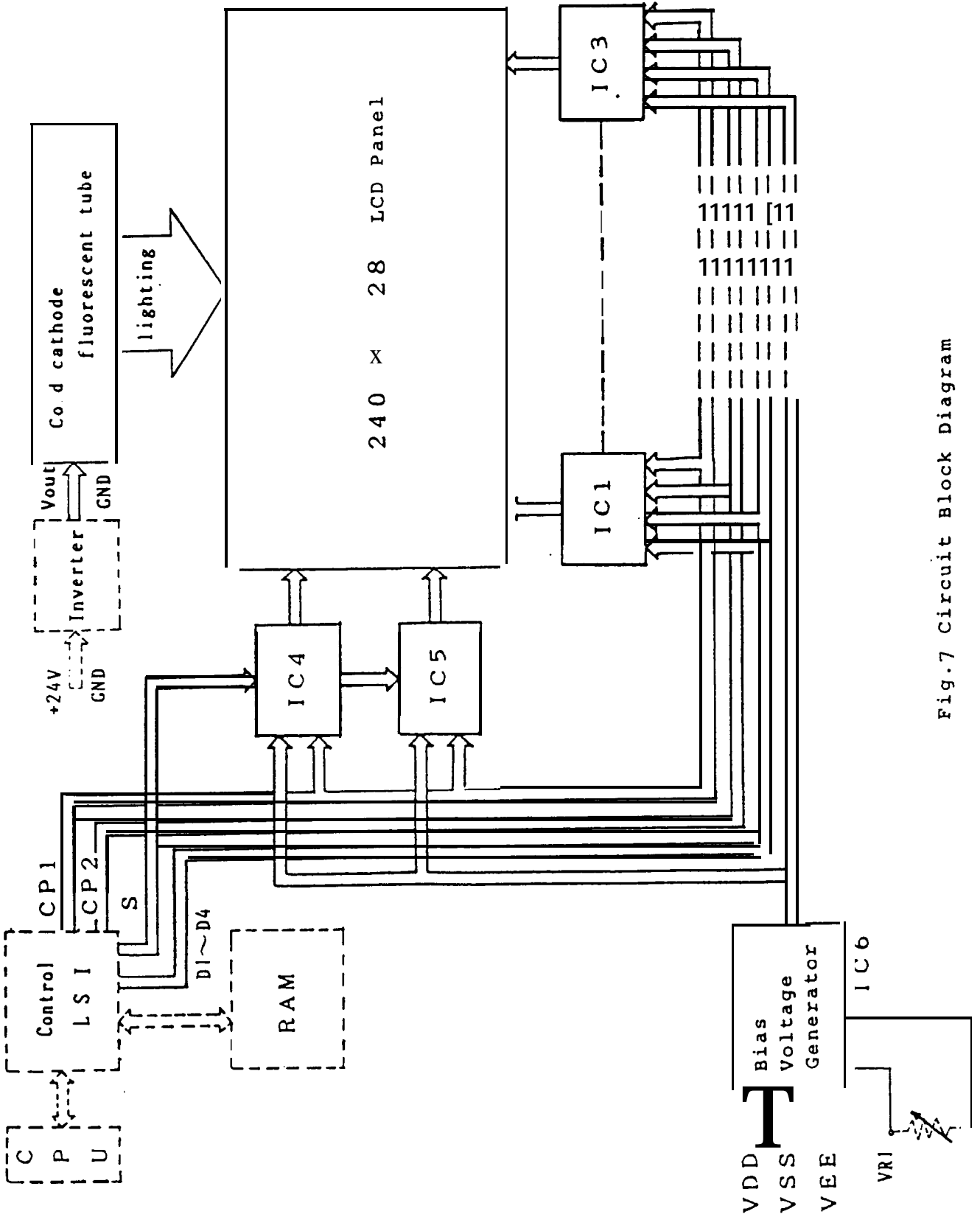
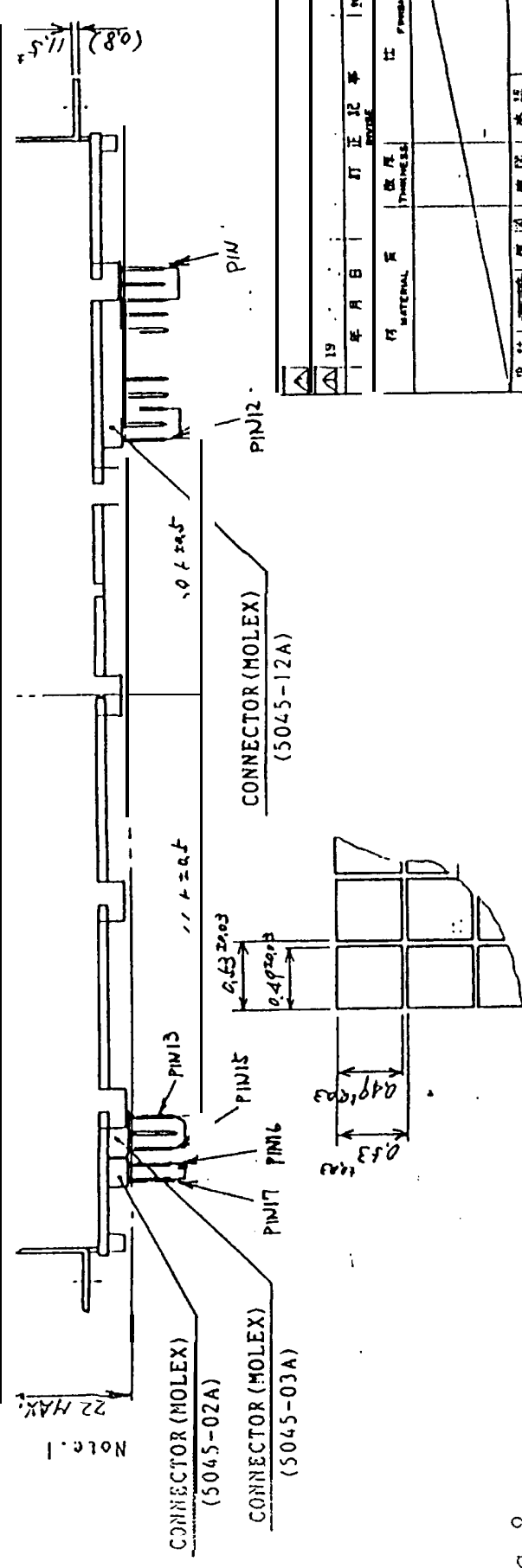
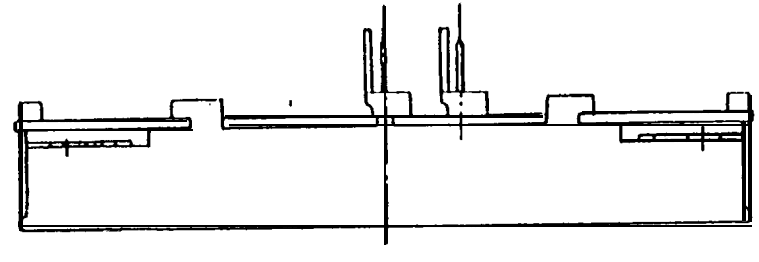
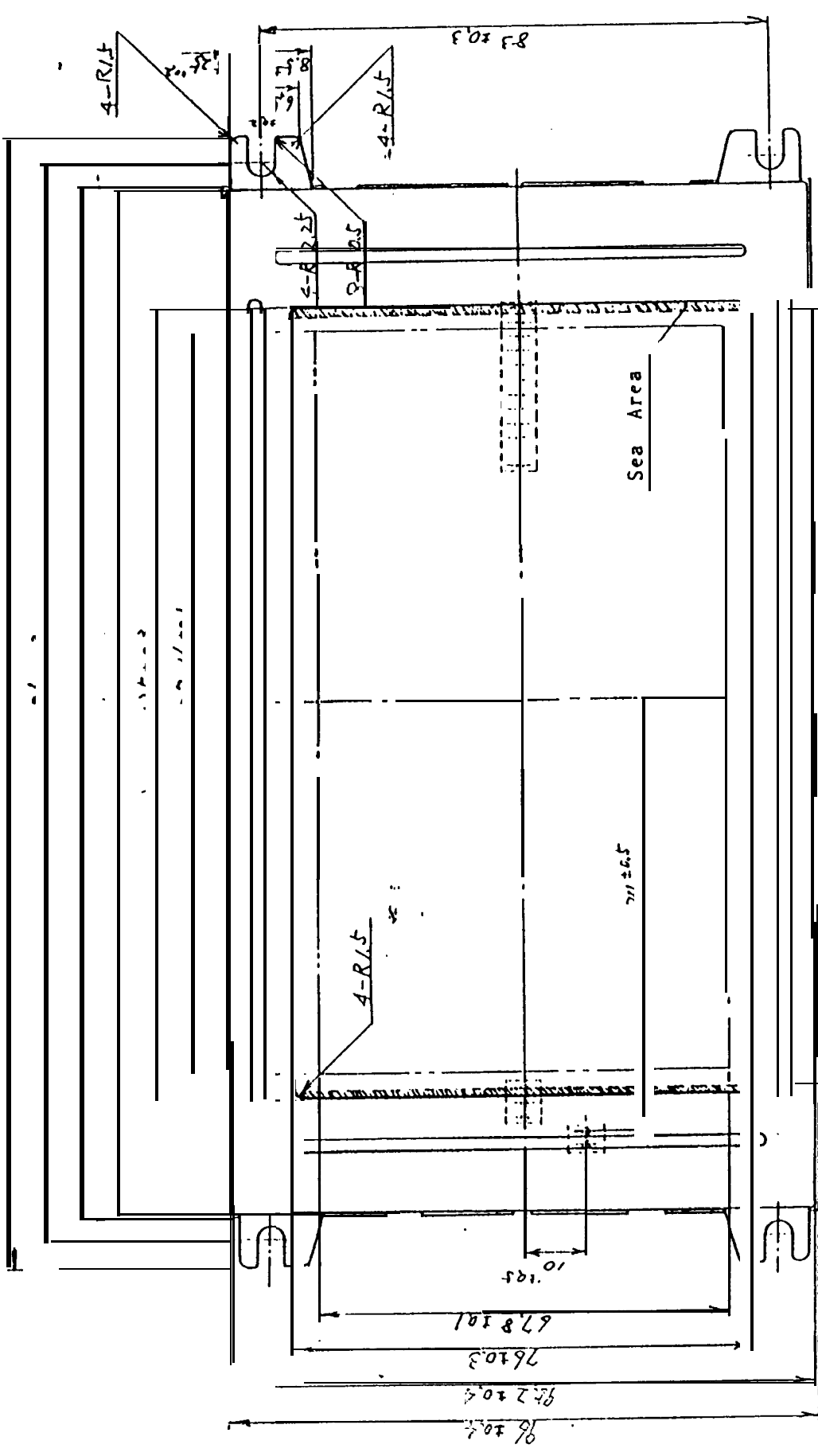

Fig.7 Circuit Block Diagram

1 2 3 5 7 8 9 10 11 12 13 14 15 16 17 18 19 20 21 22 23 24 25 26 27 28 29 30 31 32 33 34 35 36 37 38 39 40 41 42 43 44 45 46 47 48 49 50 51 52 53 54 55 56 57 58 59 60 61 62 63 64 65 66 67 68 69 70 71 72 73 74 75 76 77 78 79 80 81 82 83 84 85 86 87 88 89 90 91 92 93 94 95 96 97 98 99 100

設計通知書
DESIGN NOTIFICATION
No. () 号による
新設・変更・書換 図面
NEW CHANGE REPLACE

図名: 部品名: 数量: 材料: 仕入: 備考: 担当者: 承認者: 承認日: 図番: 024010Z010



3. The Ezzeilmetal are is galvanneal or not INTERIEN MATTERIELL.
FOR 134mm) IS NOT INSPELLEN IN VBACK
And the changed PARTLINE AREA PROTRUDING part (the area protruding is 0.34mm).

2. The seal may be visible at the shaded part.

Note 1. Maximum thickness (except connector)

指示なき寸法公差は ±0.1 とす
UNSPECIFIED TOL. TO BE ±0.1

年 月 日	訂正 記号	理由	担当者	承認者
19				

図 番	024010Z010
作 成 日 付	1988 May 16
部 品 名	液晶表示装置
部 品 代 号	024010Z010
部 品 記 号	024010Z010
部 品 記 号	024010Z010

SCALE 1/1

SHARP CORPORATION
LCD DIVISION
ENGINEERING DEPT.2

Fig. 8

SHARP

9. Precautions

9.1 **Angle** when installing the unit

This unit's viewing angle is illustrated in Fig. 9.

$$\theta_1 < \text{viewing range} < \theta_2 \quad (\theta_1 < 0^\circ, \theta_2 \geq 0^\circ)$$

(For the specific values of θ_1 , θ_2 , refer to the Table 8.)

Please consider the optimum viewing conditions according to the purpose when installing the unit.

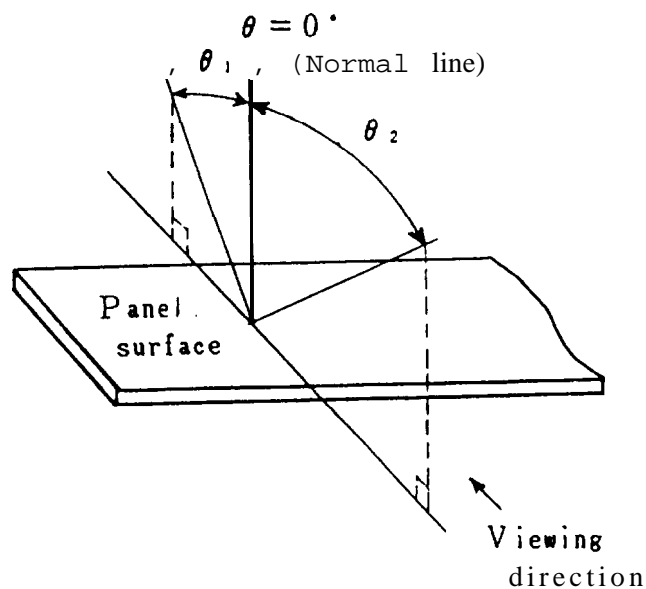

Fig. 9 Dot matrix LCD viewing angle

9.2 Handling cautions

This unit is installed using mounting tabs at the four corners of PCB or bezel.

When installing the unit, pay attention and handle carefully not to allow any undue stress such as twist or bend.

A transparent acrylic resin board or other type of protective panel should be attached to the front of the unit to protect the polarizer, LCD cells, etc.

SHARP

9.3 Notes on attachment

- (1) Since the front polarizer is easily damaged, please pay attention not to scratch on its face.
- (2) If the surface of the LCD cells needs to be cleaned, wipe it swiftly with cotton or other soft cloth. If still not completely clear, blow on it and wipe.
- (3) Water droplets, **etc.** must be wiped off immediately since they may cause color changes, staining, etc. if remained for a long time.
- (4) Since LCD is made of glass plates, dropping the unit or banging it against hard objects may cause cracking or fragmentation.
- (5) CMOS LSIS are equipped in this unit, so care must be taken to avoid the **electro** static charge, by earthing human body, etc. Take the following measures, to protect the unit from the electric discharge via mounting tabs from the main system electrified with static electricity.
 - (1) Earth the metallic case of the main system (contact of the unit and main system).
 - (2) Insulate the unit and main system by attaching insulating washers made of **bakelite** or nylon, etc.

9.4 Notes on operation

- (1) The unit should be driven according to the specified ratings to avoid malfunction or permanent damage. DC voltage drive leads to rapid deterioration of LC, so ensure that the drive is alternating **waveform**.

9.5 Others

- (1) Avoid to expose the unit to the direct sun-light, strong ultra-violet light, etc. for a long time.
- (2) If stored at temperatures below specified storage temperature, the **LC** may freeze and be deteriorated. If storage temperature exceed the specified rating, the molecular orientation of the **LC** may change to that of a liquid, and they may not revert to their original state. As far as possible always store at normal room temperature.
- (3) If the LCD panel is removed from the LCD unit, it may cause the poor contact on reinsertion. So please avoid to dismantle the unit.

SHARP

(Reference)

Specification of inverter for cold cathode fluorescent tube FLE65160(AE)B drive.

* . Rating

Supply voltage	(V_{in})	$24 \pm 10\%$ Vdc
Supply current	(I_{in})	90 ± 9 mA
Discharging tube current	(I_L)	4.4 ± 1 mA _{rms}
Discharging tube voltage (VL) reference value		290 ± 40 V _{rms}
Non loading output voltage		Min 900 V _{rms}
Frequency	(f)	Approx 33 KHz
Operating temperature	(T_a)	Min 0~45 °C
Storage temperature	(T_s)	Min -20~60 °C

* . Measurement circuit

Refer to Fig.10

* . Measurement conditions

Unspecified conditions to be 15°C~35°C/45%~85%RH.

(when ■ easurement result is critical to judge, then ● easurement at 25°C ± 1°C/65% ± 5%RH.)

Fig.10

